

PRO

SERIES

High Tensile Installation Guide



High Tensile Installation Guide

CONTENTS

Why High Tensile?	1
Successful How-To	1
Post Installation	2
Driven Posts	2
Hand-Set Posts	2
Guide Wire	3
Line Posts	4
Bracing	4-6
End Bracing	4
Brace Pins	5
Brace Wire	5
Corners	6
Wire and Wire Spacing	7
Stapling Technique	8
Electrifying Wire	9
Crimping	10
In-Line Strainers	10
Tension Springs	11
Electrical Connections	11
Poly-spacers	11
Gate Openings	12
Maintenance	12
Component Checklist	13
Fence Overview	14

WHY HIGH TENSILE?

High tensile fence is an excellent choice to safely contain most species of livestock, including various exotic species. It is also equally effective keeping unwanted predators, deer or other wild animals out.

High tensile is an affordable, low maintenance permanent perimeter fence, lasting up to 40 years. It works as a simple barrier fence, or can be electrified for greater effectiveness and animal safety.

SUCCESSFUL HOW-TO

The key to a successful high tensile fence installation is advanced planning, combined with proper tools and quality materials. We recommend PRO Series high tensile components, which are rugged, reliable and designed to withstand harsh environmental conditions, providing long life for your fence.

This brochure provides an overview of how to build and install a high tensile fence. We also recommend the PRO Series High Tensile Installation Video for a visual review. Visit zarebasystems.com or your local farm supply store to request a copy.

BEFORE YOU BEGIN

Before you begin, draw a measured or scale layout of your fence project. This will be a valuable planning aid, and help establish a materials list.

Use the Fence Builder™ interactive planning tool at the zarebasystems.com web site as a starting point for determining materials. The parts check list at the back of the brochure can also help to verify part numbers.

Be sure to locate buried hazards and any utility lines before you start digging post holes. Utility companies typically have a free One Call program that will respond within three days.

SAFETY

Be sure to follow all safety requirements including eye, hand, and foot protection. Use hearing protection when operating power augers or post drivers.

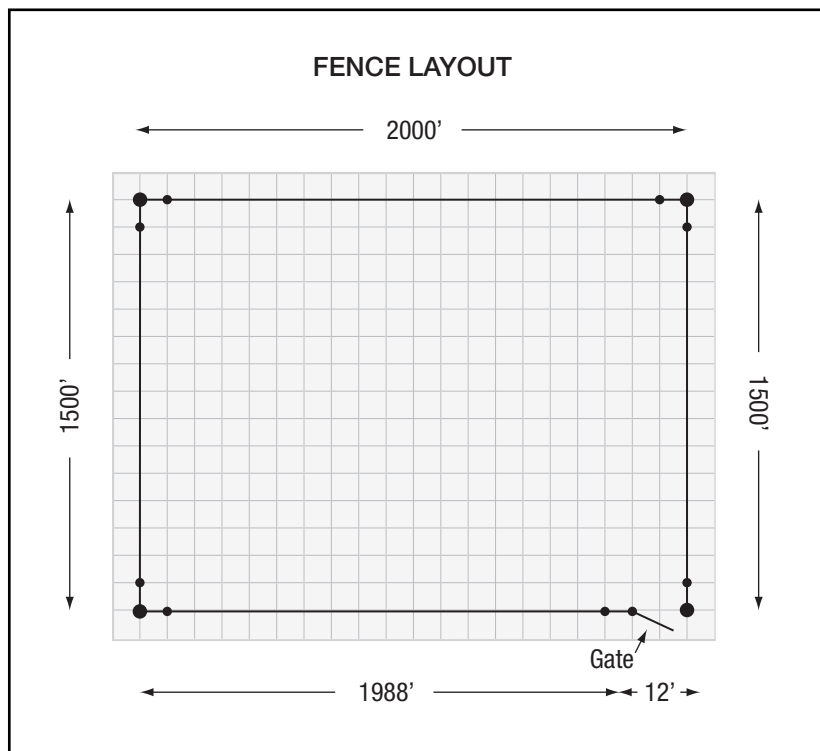

POST INSTALLATION – END, CORNER, DIP AND RISE

Start with installation of all end, corner, dip and rise posts. These posts will support the guide wire used to align the remaining line posts. You can either hand-set posts or use a hydraulic post driver. Installation will vary slightly depending on the method you choose.

END/ANCHOR POSTS

End anchor and corner posts are at least 8-feet long and generally 6 inches in diameter. They should be buried at least 42" deep and set with a 2-3" preloaded lean. These will go at each fence corner and major dips or rises in the terrain.

DRIVEN POSTS

Driven posts require a tractor or truck mounted hydraulic post driver. These posts have nearly 10 times the pull out resistance of an augered, hand set post and are recommended if equipment is available.

Pre drilling a small pilot hole in the ground using a 4" rock auger can ease post driving in hard, rocky soil conditions.

Driven posts always go into the ground small end first for the least amount of soil disruption and greater holding power.

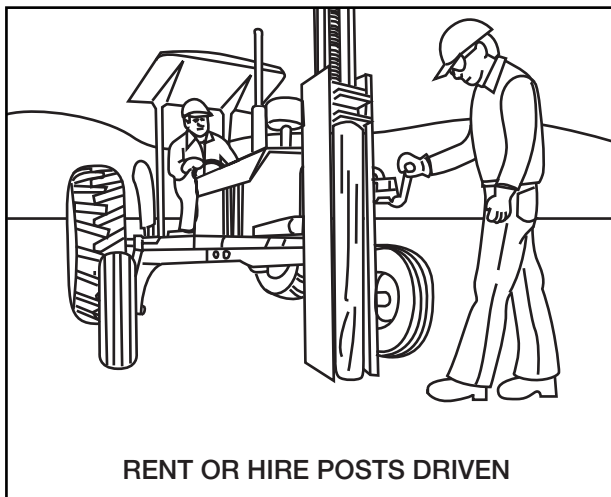
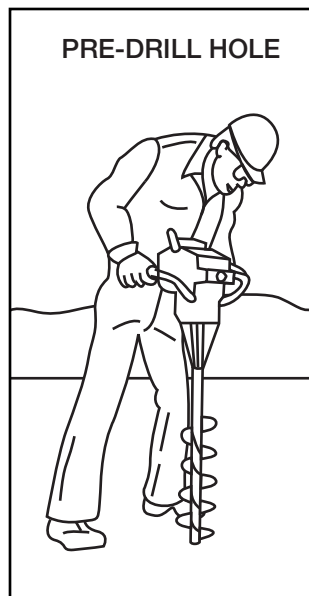

Lean posts about 2-3" away from the direction the wire will pull. This prevents the post from pulling over center when tension is applied to the wires.

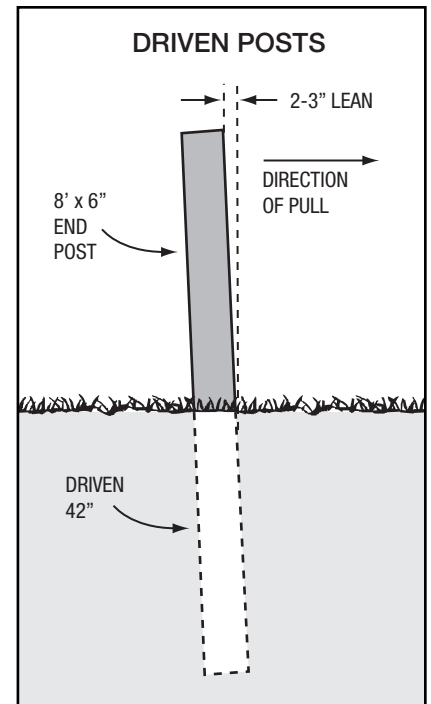

HAND-SET POSTS

You may hand set end anchor and corner posts, but must take extra steps to prevent pullout. For hand-set posts, the big end goes in the ground first for greater stability and holding power.

To anchor a hand set post, first hammer a ring of staples about 4" from the bottom of the post. The staples are driven only half way in to provide grip. Next auger a hole, then dig an inverse bell shape at the base of the hole, making sure it is at least 42" deep. Place the post in the hole and tightly tamp about 8" of dry concrete mix around the bottom. Next, tamp alternating 6" layers of soil and concrete to ground level. Over time, the soil moisture will cause the concrete mix to set up and securely anchor posts, however you can add water to speed the process.

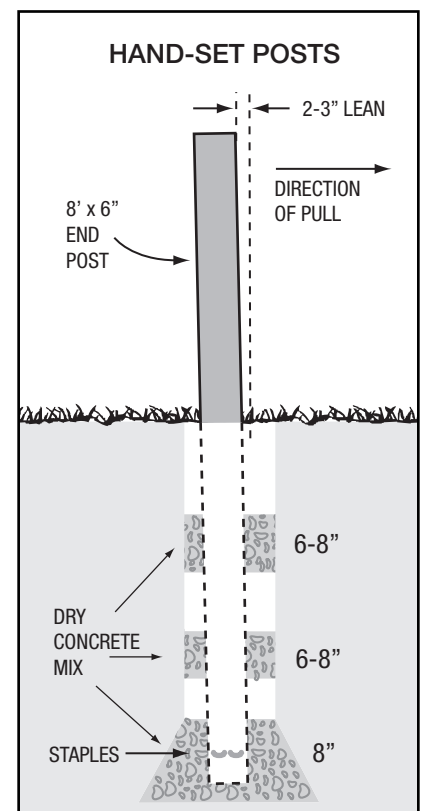

Guide Wire

STRING GUIDE WIRE

We recommend 12 1/2 gauge, 200,000 psi Class 3 galvanized wire for your fence. It normally comes in 4000-foot coils, weighing just over 100 pounds. The only practical way to install wire is to use a spinning jenny (wire de-reeler).

Place the wire on the spinning jenny, and walk along your previously installed posts, stringing wire on the side of the fence posts that will receive the animal "pressure", whether containing them or excluding them. String wire around the outside of all corner posts. Temporarily fasten to end posts at the furthest ends of the fence.

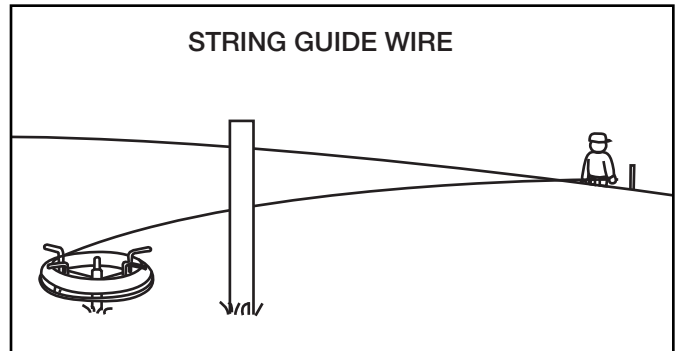

Then staple the wire to the end, dip and rise posts where you want your bottom wire positioned, generally 4-8" above the ground, depending on your wire spacing.

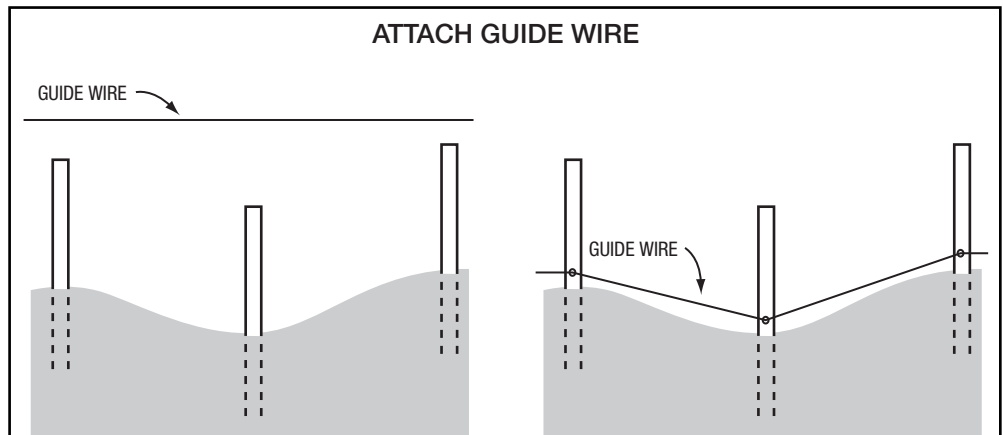

TENSION GUIDE WIRE

Attach the wire to the end post with two crimp sleeves, then tension the wire until it is about 4" off the ground or in the lowest wire position. Use a chain grab puller or install an in-line strainer to tension the guide wire.

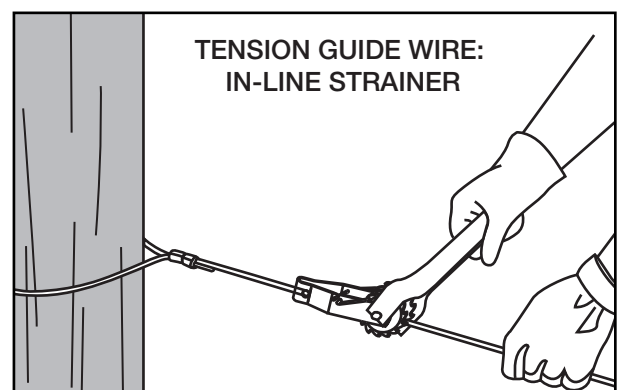
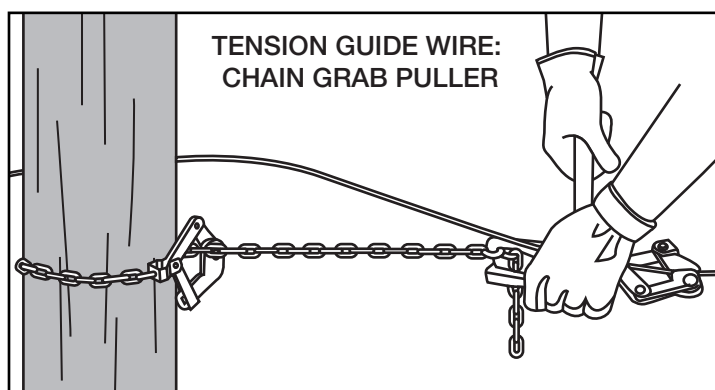
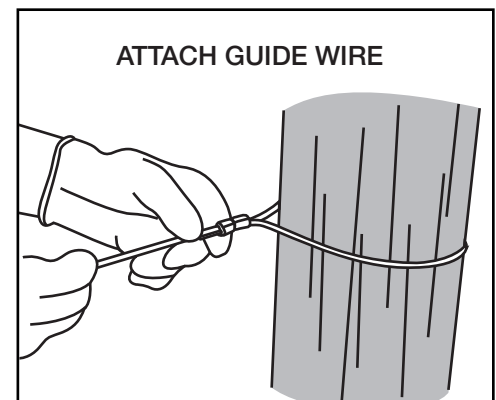

INSTALL LINE POSTS

Line posts should be at least 7-feet long and 4-inches in diameter. Using the guide wire, mark post locations with paint or flags.

As a rule of thumb, line posts are spaced about 30-feet apart but it depends on many factors including the number of wires in the fence, the terrain, as well as type and number of animals being controlled. Increasing the distance between posts reduces the cost of the fence.

When driving or setting posts in uneven terrain the posts should be set at right angles to the ground, not vertically or plum as in decorative fencing. Line posts should be driven at least 30" into the ground.

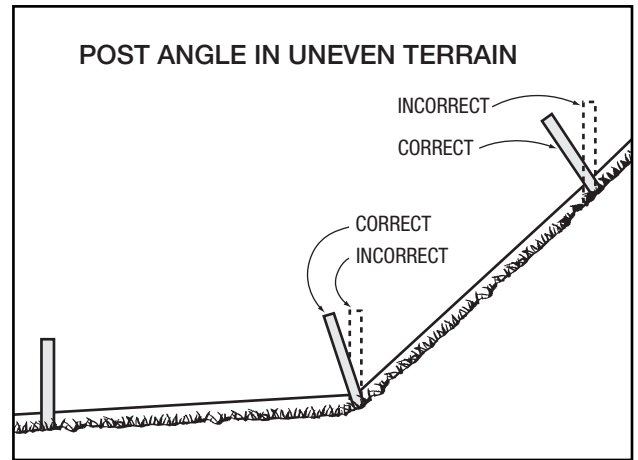

BRACING: SINGLE END BRACE

Using the first post as a guide, mark where you will drive the second end brace post, 8-feet from the first. As a rule, any fence with more than six wires requires double corner and end bracing.

A single end brace assembly works for fences of six wires or less and consists of a 6" diameter end anchor post, a 4" diameter second post, with a single 4" diameter horizontal post. Again, all 8' long.

Note that the length of the horizontal braces can affect the strength and holding ability of the entire brace assembly. Horizontal braces are generally 8-feet long, but extending this length to 10 or 12-feet can increase the holding ability of the brace assembly by as much as 50%.

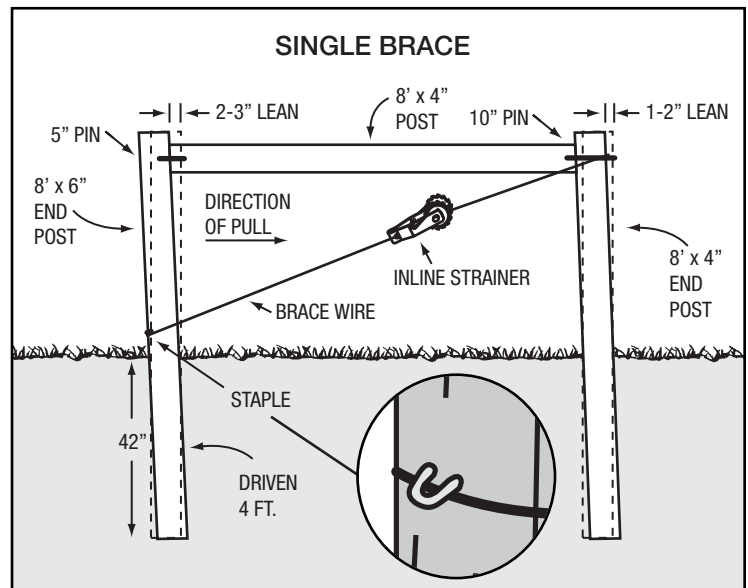

BRACING: DOUBLE END BRACE

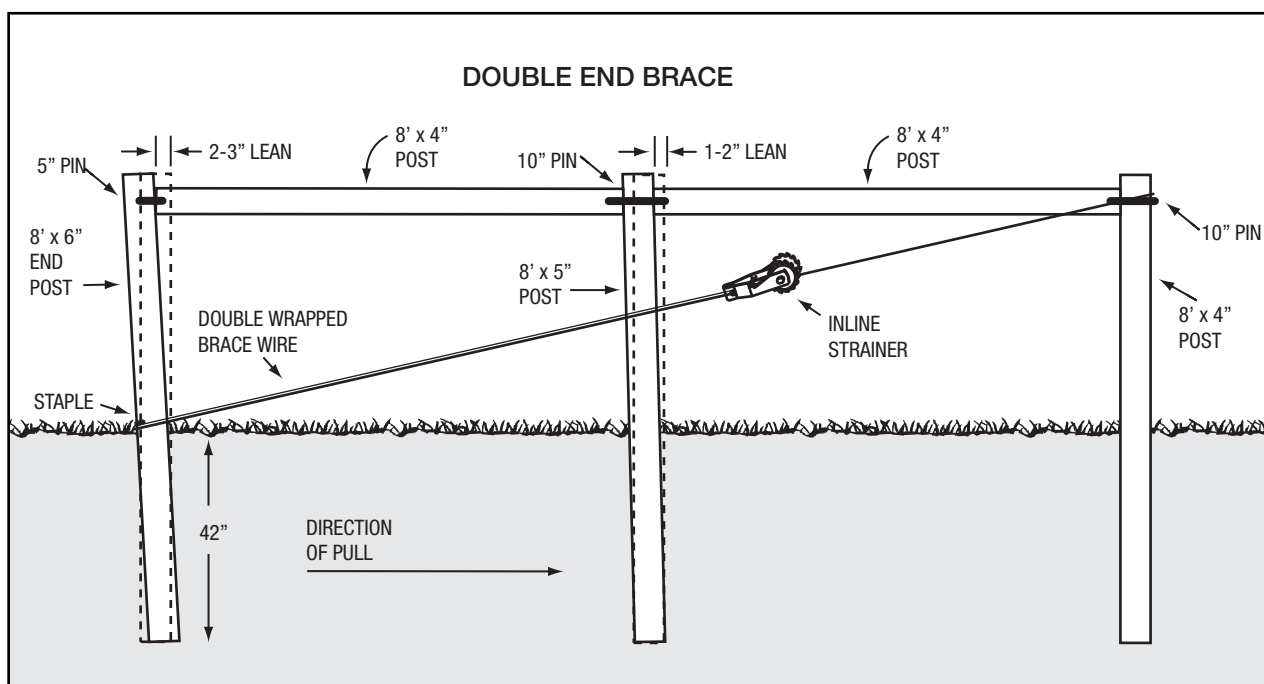

BRACING: BRACE PINS

With all vertical posts in place, measure and drill the holes for the brace pins that will hold the horizontal braces in place. These braces are best placed between the top two fence wires.

Brace pins are 3/8" diameter galvanized steel pins, in both 5" and 10" lengths.

Use a 3/8-inch diameter by 10" long drill bit. Drill into the end post approximately 2 1/2" and insert a 5" brace pin about half its length. At the second brace post, drill completely through the post and insert a 10" brace pin.

Next drill about 4" into the large end of the horizontal brace post. Slide the post onto the 5" brace pin extending from the end post. If necessary, trim it to fit snugly between the end and second vertical post.

Pound the 10" brace pin through the second brace post and into the horizontal brace. Leave about 2" exposed on the far end for anchoring the brace wire. Or, if you're building a double brace, leave the exposed pin to hang the second horizontal brace.

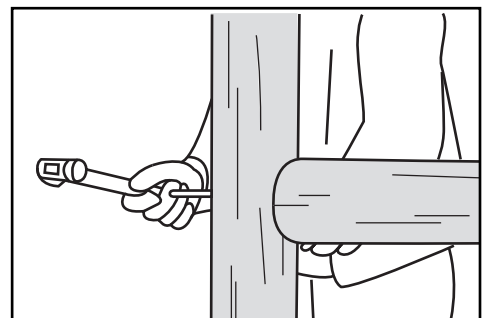
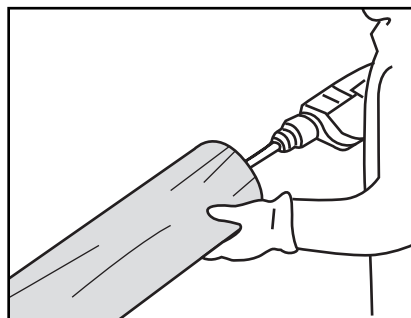
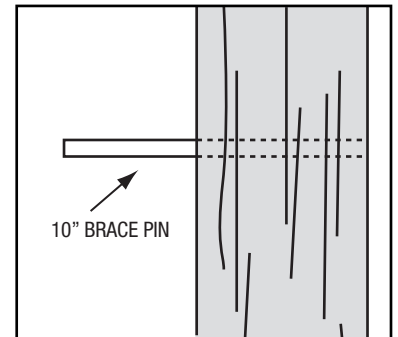
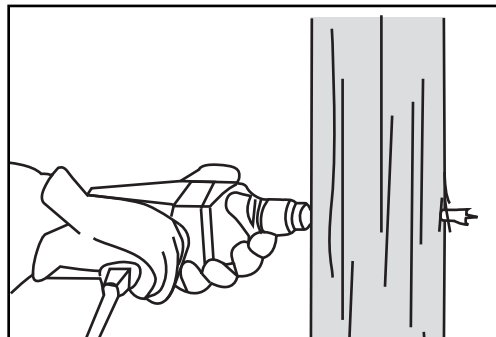
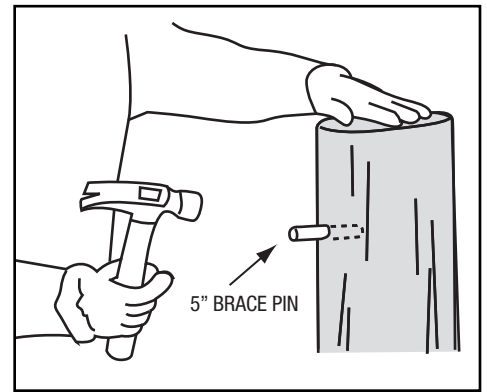
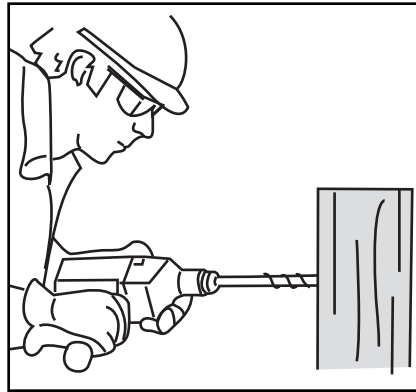

BRACE WIRE

Now that all posts are in position, it's time to install the brace wire that holds the brace together.

Drive a staple horizontally about 4" up from the ground on the outside of the end anchor post. Next, make two complete wire wraps from below the staple to the top brace pin of the second vertical brace post. For a double brace, wrap it around the center post in a figure eight pattern.

Pull out as much slack as possible. Next, install an inline strainer in the upper half of the figure-eight wire wrap and tighten the wire. Use two crimp sleeves to join the wire.

Tension the brace wire to close any gaps that may exist between the horizontal brace post, the end post and the second brace post. Be sure there is even pressure on all strands.

CORNER BRACES

A corner can be made using a common end post and building two brace assemblies at an angle from that end post.

You'll use a total of nine 8-foot-long posts to build a double corner brace, one 6" diameter end anchor post, two 5" diameter brace posts, and two 4" diameter second brace posts. The remaining four horizontal posts are all 4" in diameter.

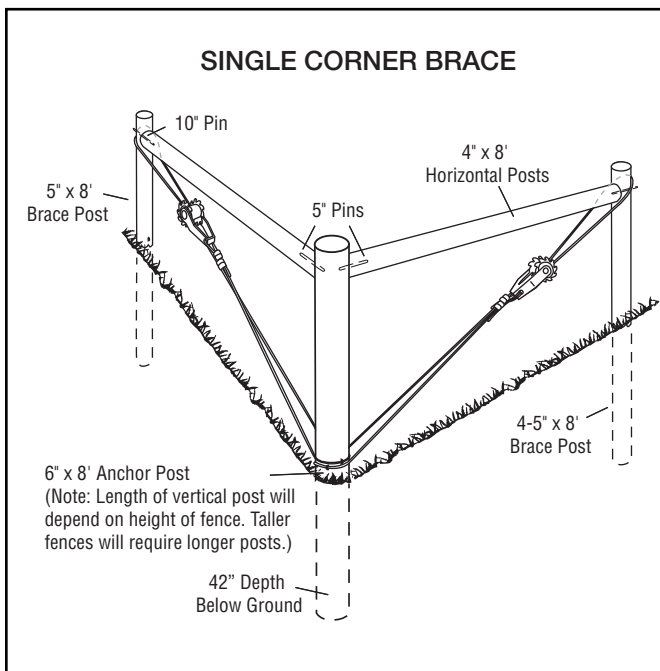
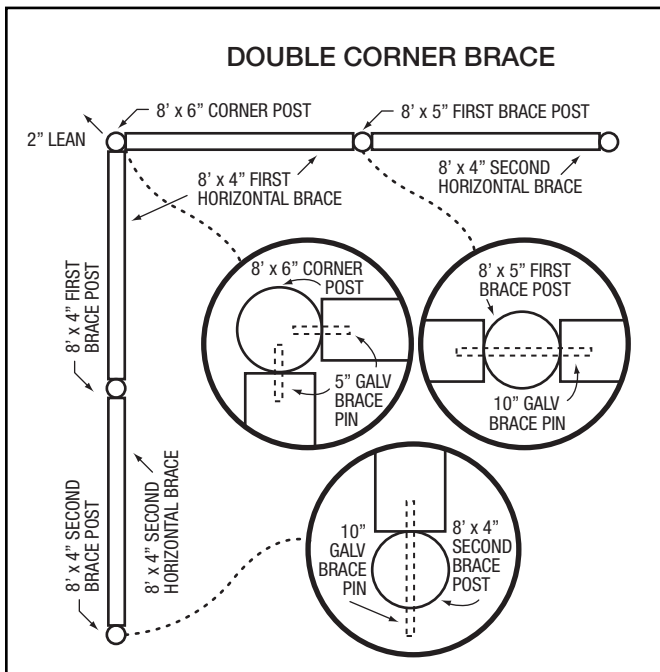

SWEEP CORNERS

Corners may also be constructed using posts leaning against the pull of the wire. For every 10-degree directional change use a 4" x 8' post on a 4" lean, 4-feet deep. For every 20-degree change use a 5" x 9' post on a 5" lean, 4 1/2 feet deep. For every 30-degree change use a 6" x 9' post on a 6" lean, 5' deep. String wire to the outside of the bend.

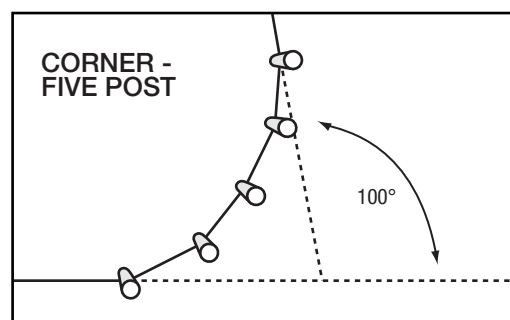
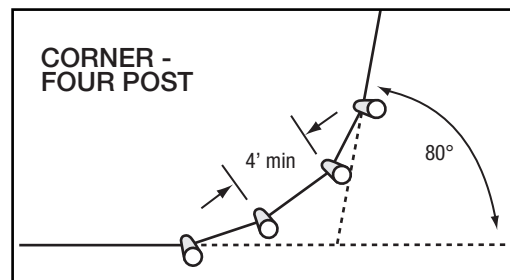
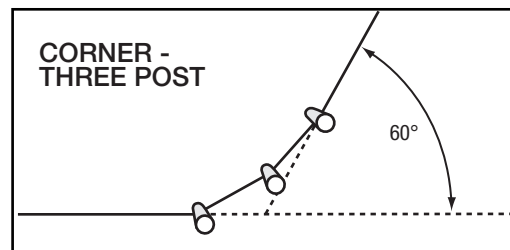
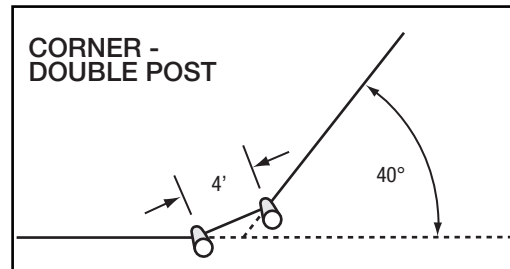
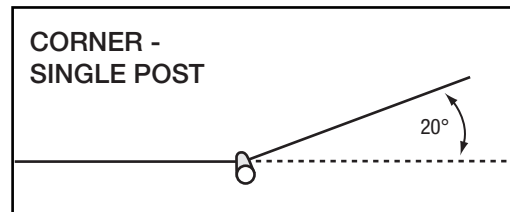

Wire Spacing

Recommended Wood Post and Poly-Spacer Spacing			
Application (stable soil)	Post Spacing	Poly-Spacer Spacing	No. of Wires
PASTURE Light Pressure	48'	12'	4 - 6
PASTURE Medium Pressure	40' 36'	10' 12'	4 - 6
PASTURE Heavy Pressure	30' 24'	10' 8'	6 - 10
CORRAL/LOT Light Pressure	20'	10'	4 - 6
CORRAL/LOT Medium Pressure	16' 12'	8' 6'	4 - 6
CORRAL/LOT Heavy Pressure	8' 6'	4' 3'	6 - 10

WIRE SPACING

High tensile wire comes in 200,000 pounds per square inch, or psi, and 170,000 psi ratings. We recommend 200,000 psi wire for its' superior breaking strength and resistance to elongation and sagging. The 170,000 psi wire is acceptable for electrified fencing, but generally isn't strong enough for non-electric configurations.

The number of wires and their spacing will vary, depending on the animal you are containing. Using a tape measure or pre-marked spacer, mark your desired wire spacing on fence posts using a lumber crayon or marker.

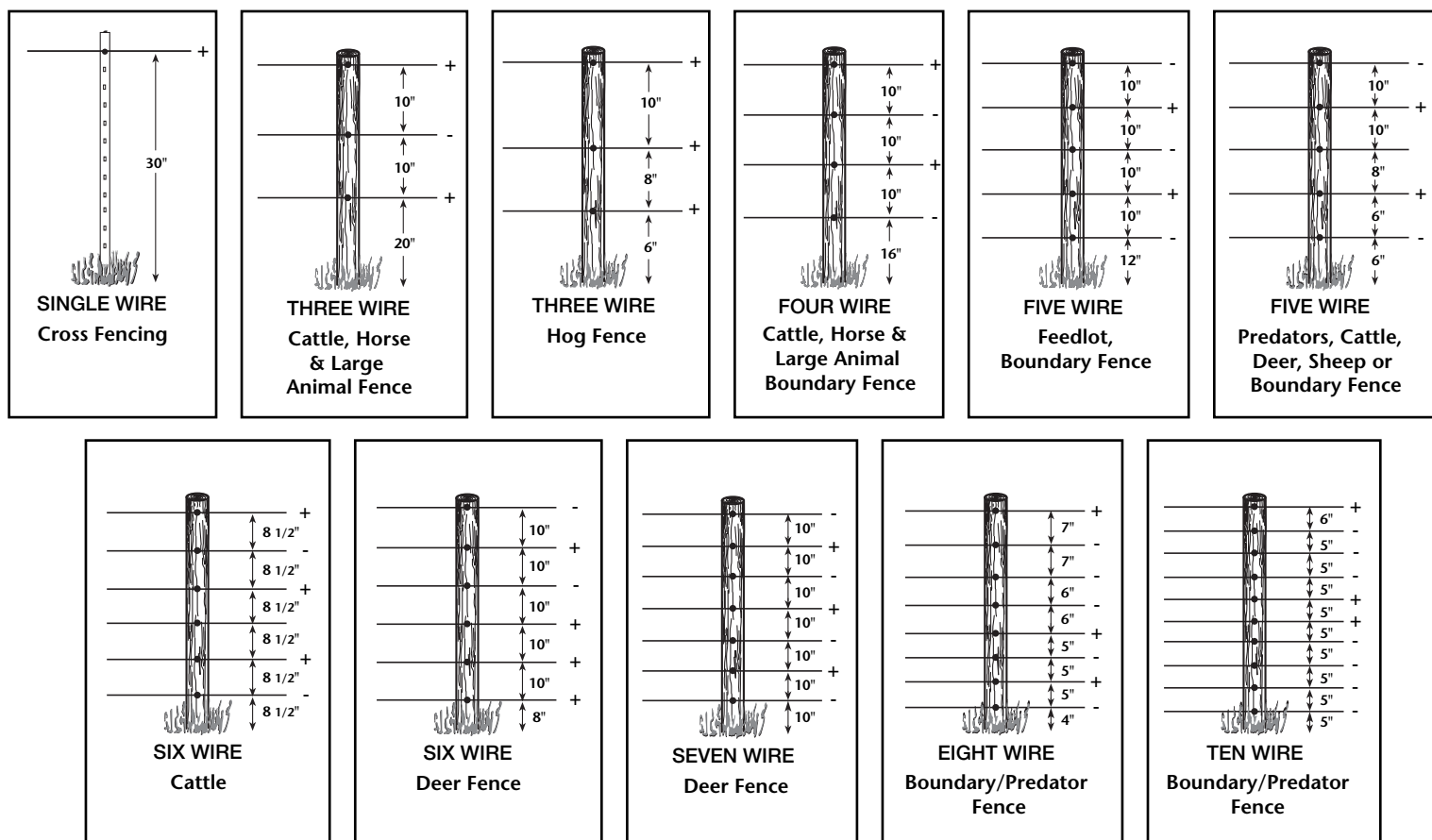

PAY-OUT WIRE

You're now ready to pay-out the fence wire along the fence-line using the spinning jenny. Before stringing wire determine which wires will be electrified so the appropriate insulator can be placed as the wire is strung. Generally, place wire on the side of the post that will have animal pressure.

To avoid wire tangling, string one strand of wire around the enclosure, and attach to posts before stringing the next wire.

The bottom wire is the guide wire, which was previously laid out, and is the first to be attached.

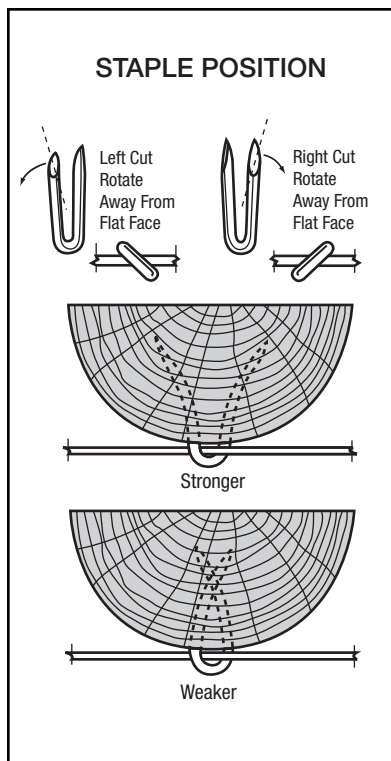

DIP POST - DOUBLE STAPLING

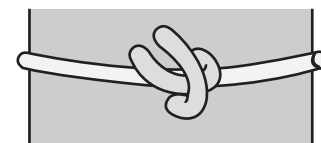

Non-Electrified Wire



Electrified Wire

RISE POST - DOUBLE STAPLING



Non-Electrified Wire



Electrified Wire

END POST - DOUBLE STAPLING

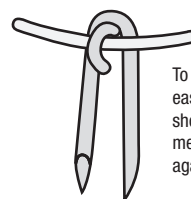

Non-Electrified Wire

To allow wires to slide more easily around a corner, they should rest loosely against metal staples rather than against the wood post.

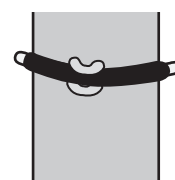

Electrified Wire

STAPLING TECHNIQUE

Attach the non-electrified high tensile wire to the line posts with staples. Be sure to use 8 or 9 gauge Class 3 galvanized barbed-type staples for longest product life. Use a slash cut staple and drive it in at a 30-45° angle so that the legs of the staple spread outward when they contact the wood grain.

Drive staples in leaving a 1/4 inch gap so that the wire can move freely beneath it. Dip and rise posts require a special double stapling technique so the wire doesn't pull the staple out of the post.

Stagger staple location so they are not all in the same grain, which may cause the post to split.

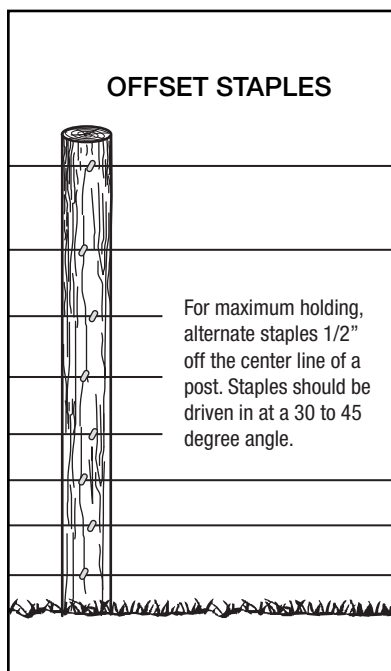

Electrifying Wire

ELECTRIFYING HIGH TENSILE FENCE

Any wire on your fence can easily be electrified, making the fence a psychological barrier as well as a physical one. Be sure one wire is positioned at the animal's nose height, causing it to back up if it touches the fence wire.

INSULATORS: LINE POSTS

You have three options to insulate the electrified wires at the line posts to prevent voltage loss. All must allow free movement of the wire, as wire expands and contracts with the seasons.

The first option is a fin tube insulator. These 4" hollow tubes have fins on the outer edge which hold it in place while allowing the wire to move freely in the tube. Fin tube insulators slide onto the wire as you string it and are attached to the post with a staple.

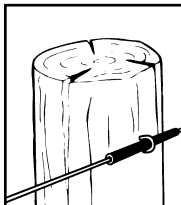

The other two insulator options are the heavy duty pin-lock or heavy duty claw insulator. These also allow the wire to slide freely and are attached to the post at pre-marked intervals. An electric drill and galvanized screws makes for speedy installation, however nails may also be used.

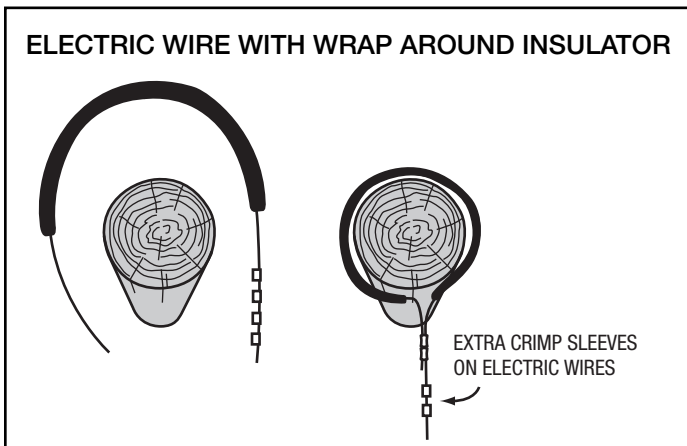
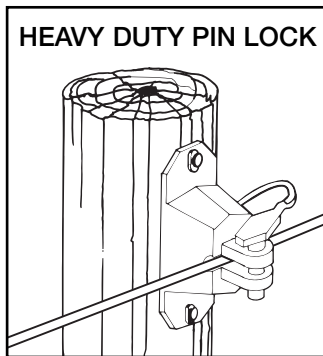
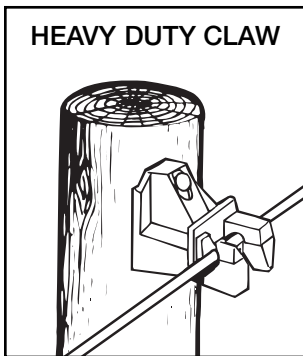

ELECTRIFIED WIRE - END POST ATTACHMENT

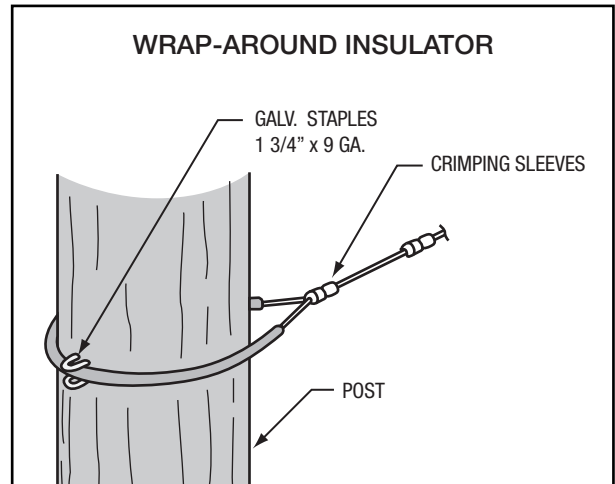

For electrified wires, use a wrap-around insulator. Position the flat side of the insulator against the post. A high strength polymer insert keeps the wire from cutting through the plastic when tension is applied to the line wires.

Slide the fence wire through the wrap-around insulator. Put 2-3 extra crimping sleeves onto the wire at this time for making electrical connections during final hook up. For an insulated electrified wire, place a staple above and below the wrap-around insulator to hold it on its pre-determined mark.

NON-ELECTRIFIED WIRE - END POST ATTACHMENT

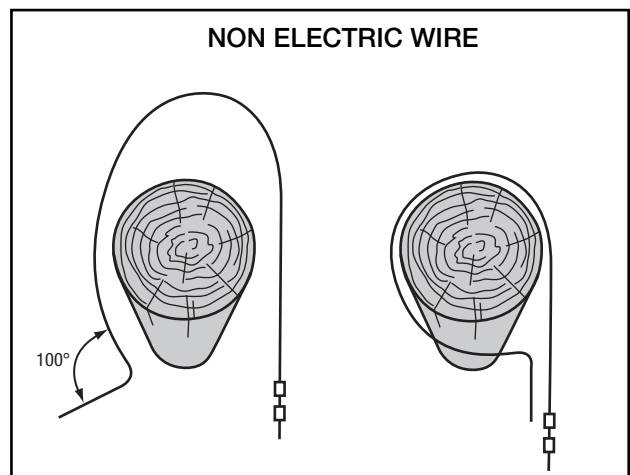

Secure each wire strand at both end posts with two 12 1/2 gauge crimping sleeves. This connection provides the same strength as the wire itself. Staple wire on it's mark.

CRIMPING

Crimping sleeves are crimped or pinched onto the wire using a specially designed crimping tool. Sleeves should be positioned tightly together for maximum holding strength. Trim wire close to end of sleeve. Gritted crimping sleeves are made from zinc plated copper with a carborundum grit inside to prevent the wire from slipping through.

As a rule of thumb, use two crimping sleeves when the wire wraps around a friction point and for in-line strainers and three crimping sleeves for an in-line splice.

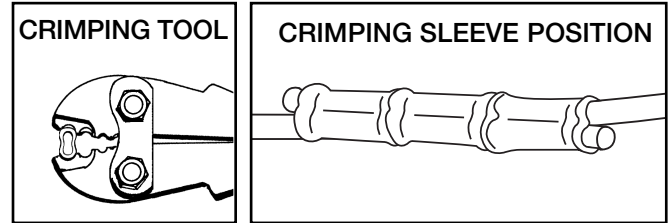

IN-LINE STRAINERS

All of the fence wire strands should now be strung around the perimeter of your fence and attached to the posts. You're now ready to install in-line strainers and apply tension to the wire. A tension indicator spring goes on the second wire from the top and is used to determine wire tension. The PRO series heavy duty strainer features a spring-loaded engagement flapper and tapered center hub for easy loading of wire.

Generally you need one in-line strainer every 4000 feet of fence. Locate strainers in the middle of a fence span, where the pull in both directions will be equal. Every friction point (corners, dips, rises) reduces the strainer's tension capacity by 500 feet.

After you've determined the in-line strainer location, cut the fence wire at that point. Place two 12 1/2 gauge crimping sleeves on one end of the wire and bend the wire back onto itself. Place the wire through the hole in the in-line strap so that it comes back onto itself, allowing the crimping sleeves to slip into place. Crimp the two sleeves to permanently attach the in-line strainer to the wire.

Place the other end of the wire through the hole in the in-line reel, leaving extra wire on the reel in the event it's needed for future repairs. The compression clip on the in-line strainer eliminates the need to put your fingers near the bale of the strainer when applying tension, which can be very dangerous.

IN-LINE STRAINER ATTACHMENT - MID-SPAN

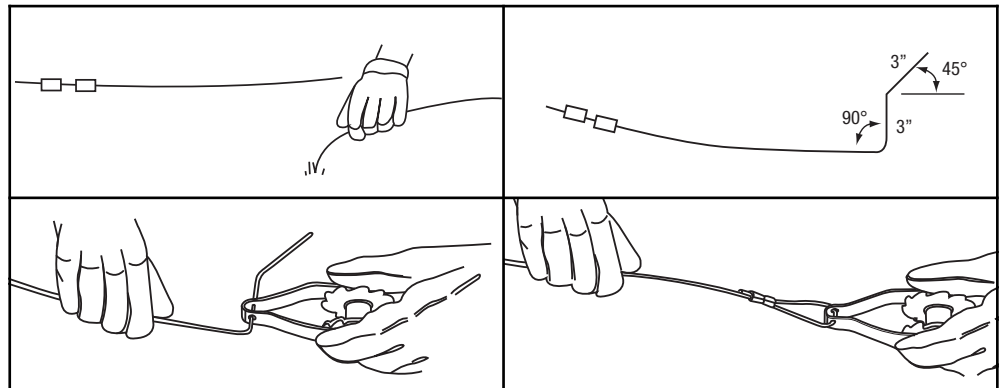
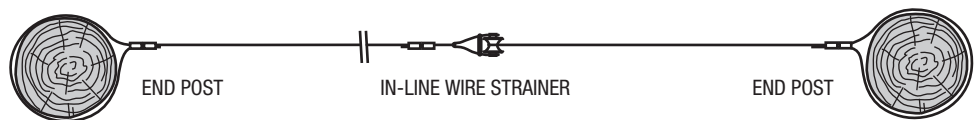

IN-LINE STRAINER ATTACHMENT - END POST

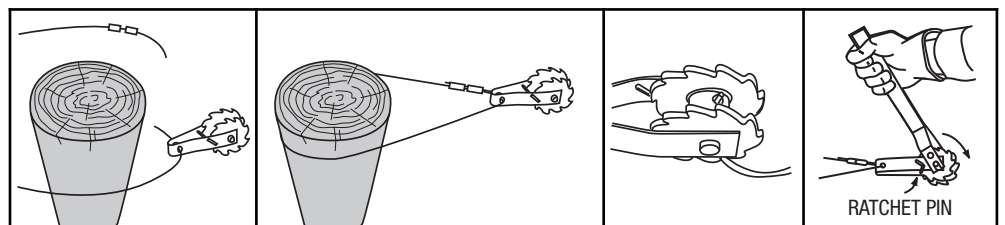

RECOMMENDED STRAINER LOCATION

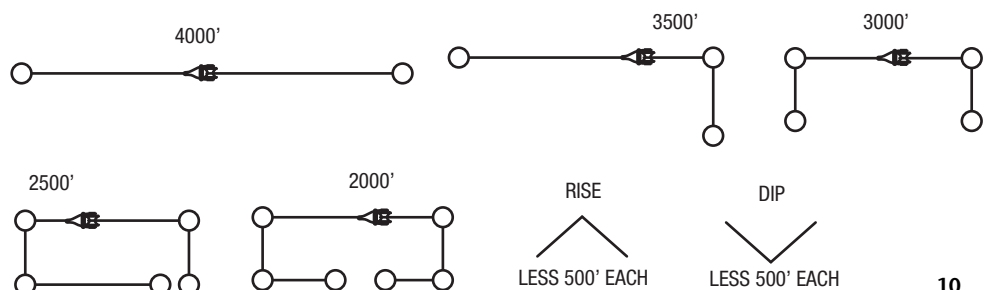

TENSION INDICATOR SPRINGS

Before tensioning the fence wire, install a tension indicator spring on the second fence wire to accurately measure wire tension. The PRO series tension indicator springs are strong, compact, and easy to use with weather resistant plating for long life. The spring features full strength tug links with marks to accurately measure wire tension.

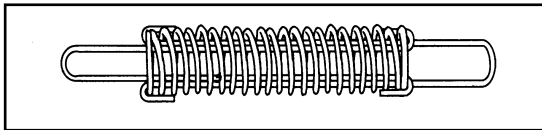

To install, pull out one tug link and thread it through the hole in the in-line strainer strap. Next reinstall the tug link back into the spring coil. Tighten the wire at the strainer using the strainer handle.

As you pull the wire toward you, the tension indicator spring will compress. The first notch indicates 150 pounds of tension, when the second notch appears, you've reached the final desired tension of 250 pounds.

Apply the same tension to all other fence wires.

INSTALL POLY-SPACERS

The next step is to install the multi-groove, poly-spacers that prevent fence wire separation between fence posts.

Place poly-spacers about 10-feet apart. They help maintain wire spacing and allow your wood line posts to be spaced further apart.

Zareba's poly-spacers are made from long lasting self-insulating UV resistant polyethylene. Multi-groove spacers are notched every inch to accommodate any wire spacing configuration. Use a Class 3 galvanized wire clip to attach spacers directly to the fence wire.

A PRO series wire twisting tool simplifies the clip installation. The multi-groove spacers are 49" in length to accommodate most farm fencing applications.

ELECTRICAL CONNECTIONS

If electrifying your fence, you need to make electrical jumper connections between all electrified fence wires.

Use a length of 12 1/2 gauge wire as a jumper and connect it to a hot wire with one of the extra crimping sleeves placed on the "hot" fence wires prior to tensioning. Crimp to attach.

Then slide a section of insulated plastic tube, or insultube, over the wire to prevent it from touching the non-electric wires. Crimp.

Repeat until all electrified wires are connected. Next, install and connect your electric fence energizer to the fence. Install indoors if AC-operated or outside in an enclosure if battery-operated. Use a low impedance energizer with adequate joules to keep animals safely contained.

Use 20,000 volt hookup wire to connect from fence terminal on energizer to the fence wire and from the ground terminal to the ground rod. For maximum fence performance, drive three 1/2" 6-foot galvanized ground rods into the ground. Space them about 10-feet apart and within 20-feet of the energizer. Connect them using 20,000 volt hookup wire and brass ground rod clamps.

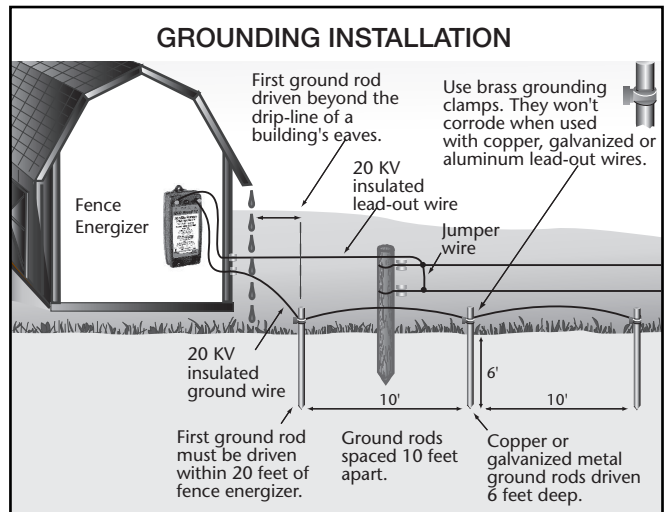

PARTS LIST – GROUNDING AND ACCESSORIES

Insultube / Hookup Wire / Gates

IT40-40' roll	Insultube
IT250-250' roll	Insultube
UGC50-50' roll	Underground Hookup Wire
UGC250-250' roll	Underground Hookup Wire
HDCSGH25-black	Compression Spring Gate Handle – Heavy Duty
SG1	Spring Gate Kit

Grounding Components

07104.96	6-foot galvanized ground rod, 1/2" diam.
GR8	8-foot copper ground rod, 1/2" diam.
07105.96	Brass ground rod clamp
Lightning Protection	
07106.96	Premium lightning diverter
LA1	Lightning Arrestor

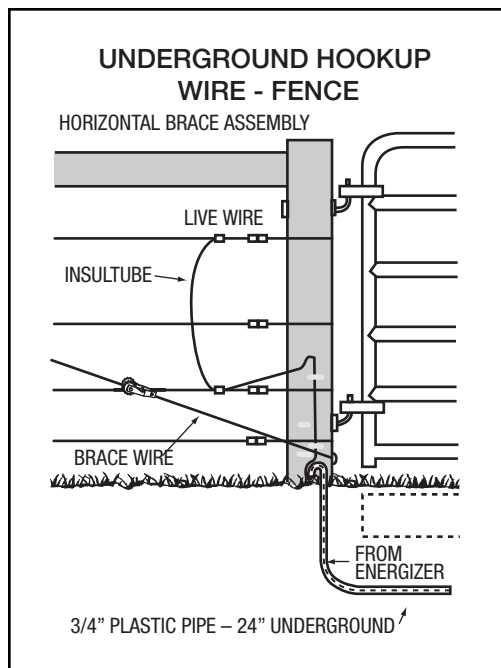

GATE OPENINGS

To create a non-electrified gate opening in your fence, bury a hot, or electrified wire under the gate opening to convey the electrical connection across the opening.

First, dig a trench across the opening at least 24" deep. Then place a heavy 3/4" poly water pipe in the trench. Next, thread a piece of 20,000 volt insulated hookup wire through the plastic pipe until it comes out the other end.

Connect the underground wire to the lowest hot wire on the fence using a fence tap or crimping sleeve. Note that fence taps can only be used for electrical connections.

Follow the same procedure on the opposite side of the gateway. Bend at least 6" of the pipe and hookup wire downward to prevent water from getting in. Fill the trench and tamp into place.

Install a metal tube or other gate as desired.

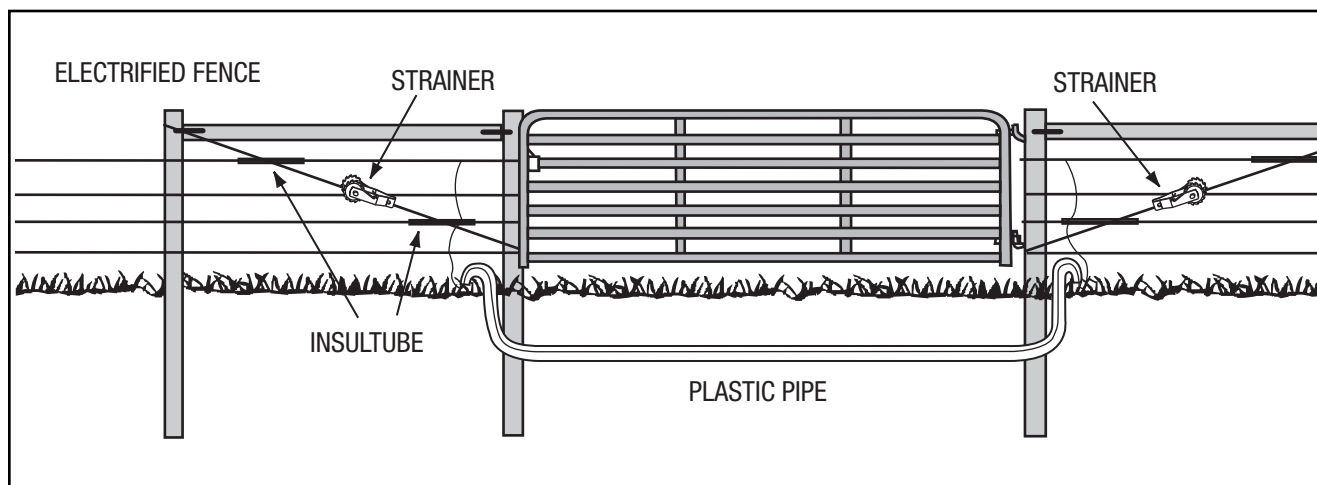

WARNING SIGNS

The last step is to attach electric fence warning signs every 300-feet or so. Many parts of the country require warning signs by law. Even if not, they are a good idea to include around your fence perimeter.

PARTS LIST – FENCE ACCESSORIES

FD1	Fence Doctor™ Electric Fence Diagnostic Tool and Short Locator
EFA1	Electric Fence Alarm
DEFT1	Digital Electric Fence Tester
RSVT8	Eight-Light Voltage Tester
COS1	Cut-Off Switch
FWF10	Warning Flags
WS100	Warning Signs

MAINTENANCE

Your high tensile fence system is now ready to provide safe and effective animal control for many years to come.

Don't forget that regularly walking your fence to check insulators and keep wire free of debris will help to keep your fence delivering top performance. Check for tree branches or weeds that may be drawing power from your fence.

A voltage tester is a good investment to help you troubleshoot short circuits and determine that adequate voltage is on the fence line.

High Tensile System Checklist

Use the following list to help determine the quantities you will need for each component. Visit your local farm retailer or fence dealer if you have further questions, or visit our website at www.zarebasystems.com.

1 Fence Controller

Select a low impedance model with sufficient energy for your fence

 (model number)

2 Posts

Corner/Gate/End Posts (assume all posts are 8' long)

Single Bracing: 6 wires or less

Each end or gate opening requires:
(1) 6", (1) 5" and (1) 4" diam. posts

Each corner requires:
(1) 6", (2) 5" and (2) 4" diam. posts

Double Bracing: 7 wires or more

Each end or gate opening requires:
(1) 6", (1) 5" and (3) 4" diam. posts

Each corner requires:
(1) 6", (2) 5" and (6) 4" diam. posts

Line Posts (assume all posts are 7' long and 4" diam)

Line post spacing (in feet)

TOTAL number of line posts
(perimeter feet divided by post spacing)
(deduct for footage used in corners/gates/ends) (total number of line posts)

TOTAL POSTS
(single brace posts + double brace posts + line posts) (total posts)

3 Fence Wire

Number of strands

Total feet needed (perimeter feet x # strands) (total feet of wire)

4 Installation Tools

You will need at least one of each tool for your installation. Depending on how many people are installing the fence, additional tools may be needed.

Spinning Jenny Wire De-Reeler (SJ1)

Wire Twisting tool (WTT1)

Fence Wire Cutter (FWC1)

4-Slot Crimping Tool (4SCT1)

Strainer Handle (SH1)

Chain Grab Wire Puller (CG1)

5 Insulators

Wood Line Post Insulators –

Fin Tube Insulator (FTI200)

Heavy Duty Pin-Lock Insulator (HDPL100 Black or WHDPL100 White)

Heavy Duty Claw Insulator (HDCL100 Black or WHDCL100 White)

number of line posts x number of electrified strands + number of vertical brace posts =
TOTAL number of line post insulators needed (number of line insulators)

Corner and End Post Insulators

Wrap Around Insulator (WAI100 BULK)

number of corner, end or gate posts x number of electrified strands =
TOTAL number of of corner/end post insulators needed (number of corner/end insulators)

6 Fence Hardware

In-Line Strainer (ILS1 or ILS10)

1 per wire strand every 4,000 perimeter feet of fence wire (add 500 feet to perimeter distance for each corner, dip, bend) (number of strainers)

Large Tension Spring (LTS1)

One per set of in-line strainers determined above (number of tension springs)

Gritted Crimping Sleeves (GCS23100)

number of sleeves needed = number of strands x (number of gate posts + number of end posts) x 3 (crimp sleeve size)

PLUS
number of strands x number of in line strainers x 2

PLUS
number of strands x number of wire splices x 3

TOTAL crimp sleeves needed (total number of crimp sleeves)

Poly Spacer (PS4925)

number of line posts x 2 (on average)

Poly Spacer Wire Clip (PSWC1000)

number of poly-spacers x # of strands

Fence Wire Taps (FWT10)

number of wire taps = number of electrical connections required

5-Inch or 10-Inch Galvanized Brace Pin (GBP5 or GBP10)

number of corner posts x 2 = number of 5" pins needed (number of 5" pins)

number of vertical brace posts = number of 10" pins needed (number of 10" pins)

Duck Bill Anchor (DBA1)

As needed to anchor posts in loose or moist soil and dips

Barbed Staples (BS5)

If using tube insulators: number of wood posts x number of wire strands +10% (number of staples)

If pin lock or claw insulators: number of wood posts x number of non-electrified wire strands +10% (number of staples)

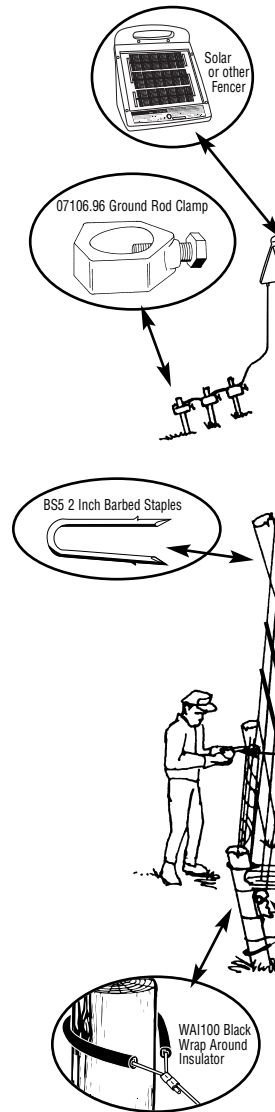

High Tensile Installation Guide

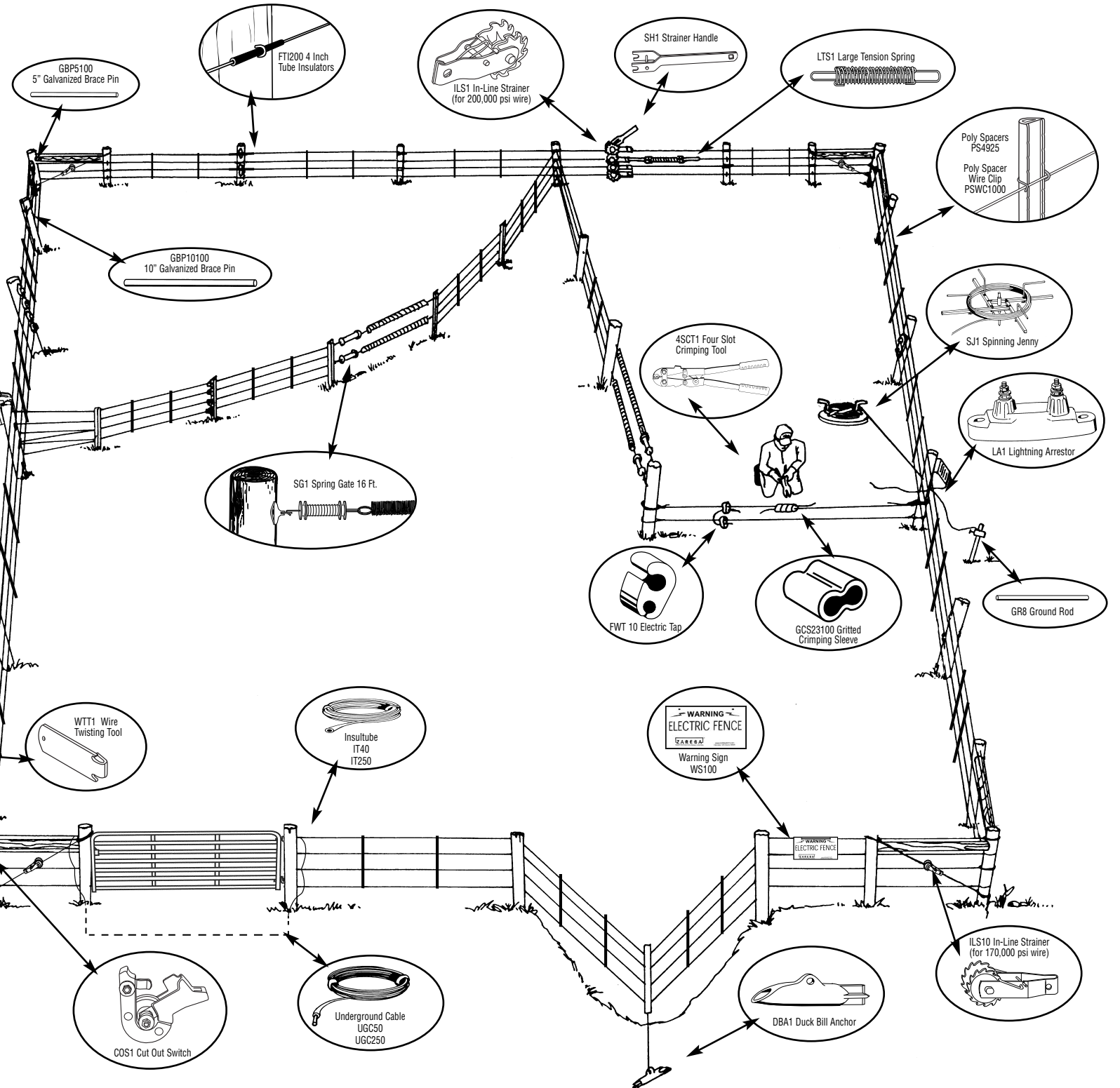

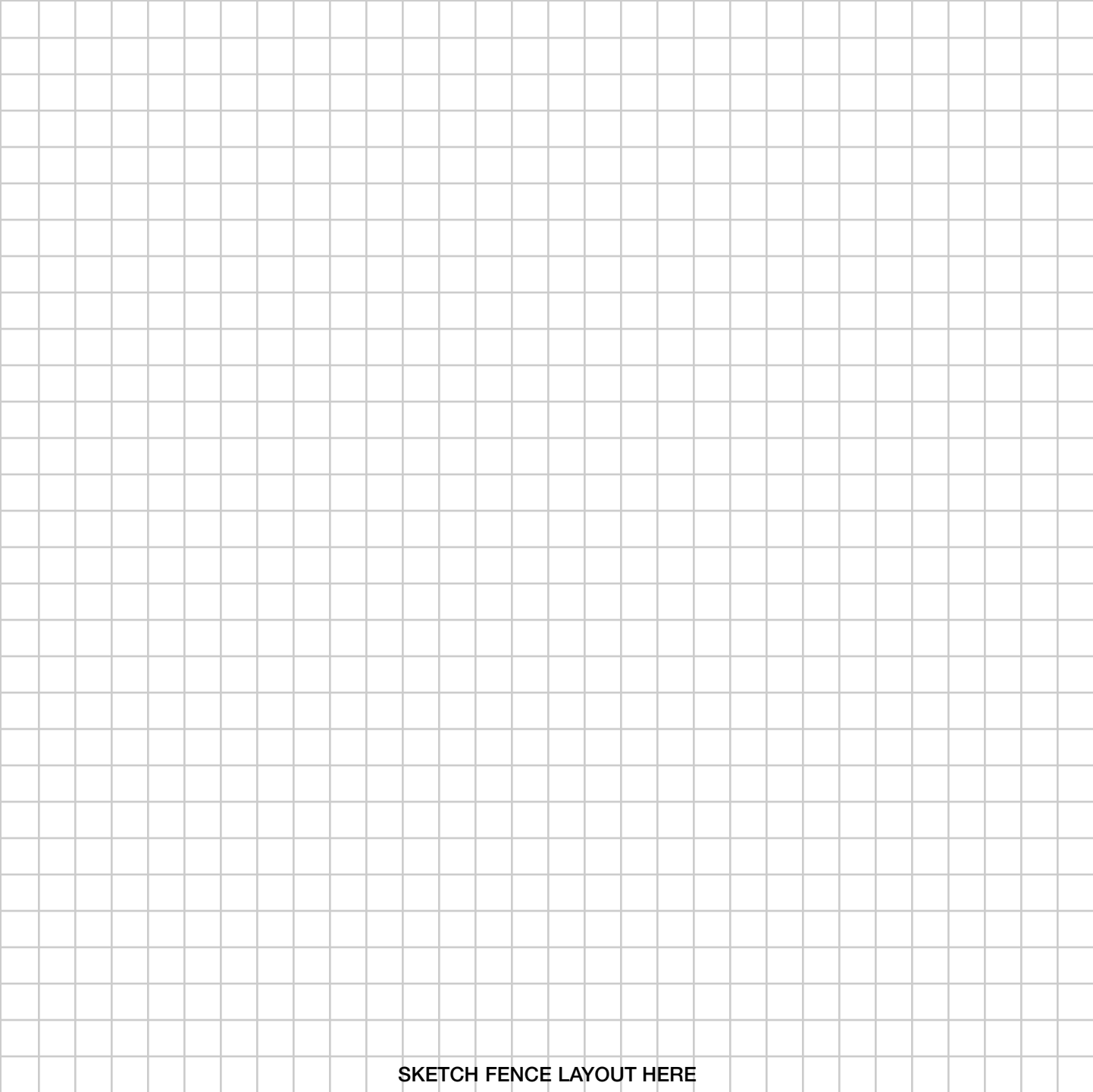

SKETCH FENCE LAYOUT HERE



We are proud
to support FFA

zarebasystems.com
Zareba Systems, Ellendale, MN 56026
1.800.272.9877

©2004

WZ-016-04

Although the information and recommendations in this High Tensile Installation Guide is presented in good faith and believed to be correct, Zareba Systems makes no representations or warranties as to the completeness or accuracy of the information.

Information is supplied upon the condition that the persons receiving same will make their own determination as to its suitability for their purposes prior to use. In no event will Zareba Systems be responsible for damages of any nature whatsoever resulting from the use of or reliance upon this information.